

Adjustable 6-Pocket, 2-Tiered Clear Acrylic Counter Brochure Holder

Product #: FLMI00218

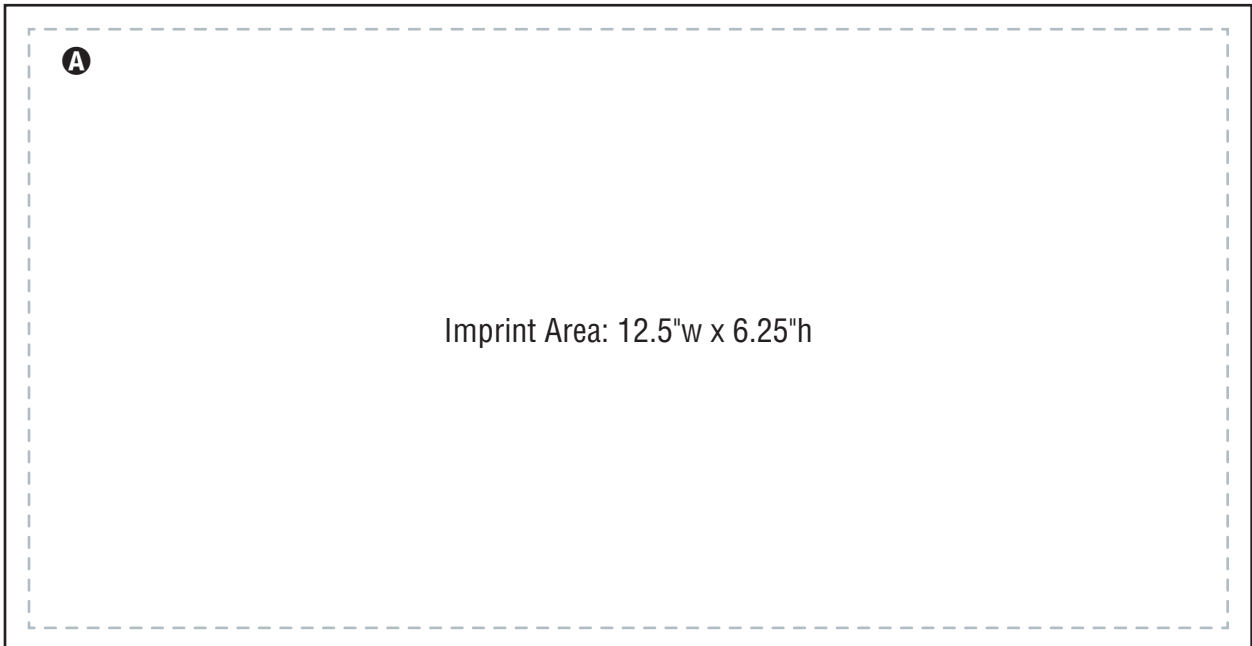
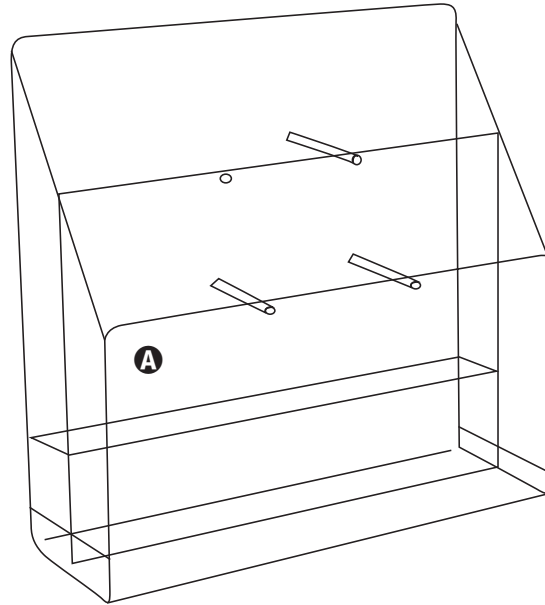

PLEASE NOTE: The measurements displayed on this template and the website are approximate. The actual display may slightly vary. We recommend ordering a sample unit to work with if your imprint has very specific positioning. Any questions, please call & our customer service team will be more than happy to assist you.